

OPERATION MANUAL



MANUAL RING ROLLING MACHINE

Model. RR-5G

Order Code S680

EDITION No : RR-5G-2

DATE OF ISSUE : 10/2022

MACHINE DETAILS

MACHINE	Manual Ring Rolling Machine
MODEL NO.	RR-5G
SERIAL NO.	
DATE OF MANF.	

DISTRIBUTED BY



www.machineryhouse.com.au

www.machineryhouse.co.nz

NOTE:

This manual is only for your reference. At the time of the compiling of this manual every effort to be exact with the instructions, specifications, drawings, and photographs of the machine was taken. Owing to the continuous improvement of the HAFCO METALMASTER machine, changes may be made at any time without obligation or notice. Please ensure the local voltage is the same as listed on the specification plate before operating any electric machine.

SAFETY SYMBOLS

The purpose of safety symbols is to attract your attention to possible hazardous conditions

WARNING Indicates a potentially hazardous situation causing injury or death

CAUTION Indicates an alert against unsafe practices.

Note: Used to alert the user to useful information



Fig.1

NOTE:

In order to see the type and model of the machine, please see the specification plate. Usually found on the back of the machine. See example (Fig.1)

PRODUCT SPECIFICATIONS	
Model: RR-5G	
Capacity: 25 X 4.7/125 Flat 5.0mm Round	Nett Weight: 5.5kg MFG Date:
Serial No:	<input type="text"/>
Imported by www.machineryhouse.com.au	Made in China www.machineryhouse.co.nz

1.1 SPECIFICATION

Order Code	S680
MODEL	RR-5G
Driven Rolls (Qty)	2 x Manual
Bending Rolls (Type)	Manual Bottom Right
Flat Bar Capacity - MS (size / Ø) (mm)	25 x 4.7 / 125
Round Bar Solid Capacity - Mild Steel (size / Ø)	Ø5 / 125
Dimensions (L x W x H) (mm)	360 x 190 x 180
Requires Additional Tooling (No/Yes)	No
Shipping Dimensions (L x W x H) (cm)	36 x 19 x 18
Net Weight (Kg)	5.5

1.2 IDENTIFICATION

Become familiar with the names and locations of the controls and features shown below to better understand the instructions in this manual.

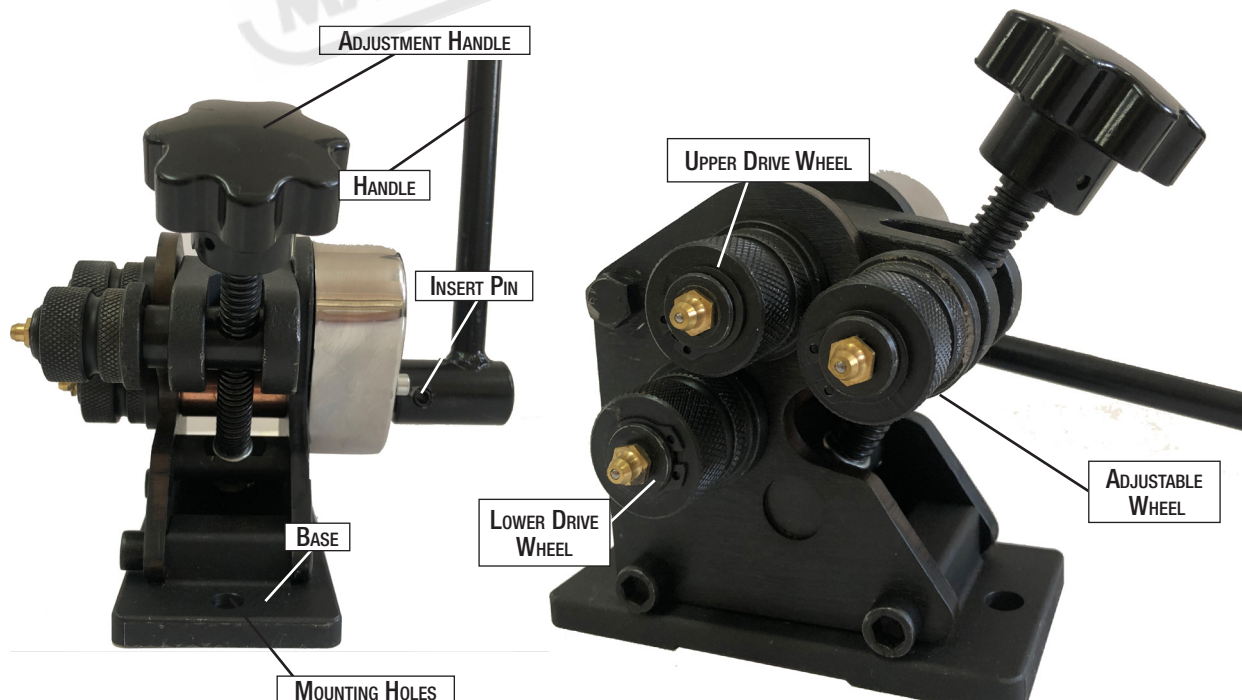

GENERAL MACHINE SHOP SAFETY WARNINGS AND PRECAUTIONS

 **WARNING** *When using tool, basic safety precautions should always be followed to reduce the risk of personal injury and damage. Read all instructions before using this tool !*

- 1. Keep the work area clean.** Cluttered areas invite injuries.
- 2. Observe work area conditions.** Do not use machines or power tools in damp or wet locations. Do Not expose to rain. Keep work area well lite. Do not use electrically powered tools in the presence of flammable gases or liquids.
- 3. Keep children away.** Children must never be allowed in the work area. Do not let them handle machines, tools, or extension cords.
- 4. Store idle equipment.** When not in use, tools must be stored in a dry location to inhibit rust. Always lock up tools and keep out of reach of children.
- 5. Do not force tool.** It will do the job better and more safely at the rate for which it was intended. Do not use inappropriate attachments in an attempt to exceed the tool capacity.
- 6. Use the right tool for the job.** Do not attempt to force a small tool or attachment to do the work of a larger industrial tool. Do not modify this tool and do not use this tool for a purpose for which it was not intended.
- 7. Dress properly.** Do not wear loose clothing or jewelry as they can be caught in moving parts. Protective, electrically non-conductive clothes and non-skid footwear are recommended when working. Wear restrictive hair covering to contain long hair.
- 8. Use eye and ear protection.** Always wear ANSI approved impact safety goggles. Wear a full face shield if you are producing metal filings or wood chips. Wear an ANSI approved dust mask or respirator when working around metal, wood, and chemical dusts and mists.
- 9. Do not overreach.** Keep proper footing and balance at all times. Do not reach over or across running machines. Keep hands and fingers clear of the Roll Dies when operating.
- 10. Maintain tools with care.** Keep tools sharp and clean for better and safer performance. Follow instructions for lubricating and changing accessories. Inspect tool cords periodically and, if damaged, have them repaired by an authorized technician. The handle must be kept clean, dry, and free from oil and grease at all times.
- 11. Remove adjusting keys and wrenches.** Check that keys and adjusting wrenches are removed from the tool or machine work surface before plugging it in.
- 12. Stay alert.** Watch what you are doing, use common sense. Do not operate any tool when you are tired.
- 13. Check for damaged parts.** Before using any tool, any part that appears damaged should be carefully checked to determine that it will operate properly and perform its intended function. Check for alignment and binding of moving parts; any broken parts or mounting fixtures; and any other condition that may affect proper operation. Any part that is damaged should be properly repaired or replaced by a qualified technician. Do not use the tool if any switch does not turn on and off properly.
- 14. Replacement parts and accessories.** When servicing, use only identical replacement parts. Use of any other parts will void the warranty. Only use accessories intended for use with this tool.

- 15. Do not operate tool if under the influence of alcohol or drugs.** Read warning labels if taking prescription medicine to determine if your judgment or reflexes are impaired while taking drugs. If there is any doubt, do not operate the tool.
- 16. Maintenance.** For your safety, service and maintenance should be performed regularly by a qualified technician.
- 17. Workpiece may be sharp.** After bending or cutting workpieces use caution. Be aware of sharp edges or sharp shreds of metal that may be created. Use heavy duty gloves when handling the workpiece.

⚠ WARNING *The warnings, cautions, and instructions discussed in this instruction manual cannot cover all possible conditions and situations that may occur. It must be understood by the operator that common sense and caution are factors which cannot be built into this product, but must be supplied by the operator.*

ADDITIONAL SAFETY FOR RING ROLLING MACHINES

DO NOT use this machine unless you have been instructed in its safe use and operation and have read and understood this manual



Safety glasses must be worn when operating this equipment



Long and loose hair must be contained when operating this equipment.



Safety footwear must be worn when operating this equipment



Close fitting/protective clothing must be worn when operating the machine

PRE-OPERATIONAL SAFETY CHECKS

- Locate and ensure you are familiar with all machine operations and the controls.
- Ensure all guards are fitted, secure and functional. Do not operate if guards are missing or faulty.
- Working parts should be well lubricated and the rolls are free of rust and dirt.
- Check workspaces and walkways to ensure no slip/trip hazards are present.
- Be aware of other people in the area and ensure the area is clear before using equipment.

OPERATIONAL SAFETY CHECKS

- Adjust the chosen rollers slowly and in small adjustments.
- Take care during the initial feeding of the workpiece into the rollers.
- Hold the workpiece sufficiently far back from the edge being fed into the rolls, to allow for the in feed speed of the machine.
- Adjust the rollers at a slow even rate. Be aware of rotating rolls
- Only one person may operate this machine at any one time.

UNPACKING AND ASSEMBLY

When unpacking, check to make sure that all parts shown in the Parts Diagram are included. If any parts are missing or broken, please contact the local dealer.

The Ring Roller will require minor assembly prior to operation. It is important that you read the entire manual to become familiar with the machine, BEFORE you assemble and use the machine. Before assembling your Ring Roller, be sure that you have all parts described in the Parts List.

When assembling your Ring Roller, refer to the Parts List and Assembly Diagram on the last pages of this manual.

Any attachment must be based on the intended use of the Ring Roller only.

MOUNTING SURFACE:

The mounting surface must be flat, level and capable of supporting the weight of the Roller, combined with the materials to be rolled. Mount the Ring Roller on a solid mounting surface that is capable of supporting the weight of the Ring Roller and the leverage force of the Handle movement.

1. Slide the Handle (15#) onto the Drive Shaft (17#), make certain that the holes in the Handle (15#) line up with the hole in the Drive Shaft II (17#).



2. Secure the Handle (15#) to the Drive Shaft (17#) using the Taper Pin (20#). Insert the Taper Pin (20#) into the hole as seen in the Figure above. If necessary, lightly tap the Taper Pin (20#) into place.

MOUNTING

1. Set the Roller on your appropriate mounting surface as desired.

WARNING *The Manual Ring Roller must be securely mounted to an appropriate work surface prior to use!*

2. Make certain that you can operate the Handle (15#) comfortably.
3. Mark out the mounting holes through the two holes located at the far ends of the Base (25#).
4. Remove the Metal Ring Roller from the appropriate mounting surface. Drill holes through the mounting surface at the marked locations.
5. Mount the machine using two bolts, lock washers, washers and nuts (not supplied.)



OPERATION

When operating your Manual Section Rolling Machine, do not force the tool or attachment to do the work of a larger industrial tool. It is designed to do the job better and more safely at the rate for which it was intended.

1. Determine the size ring you wish to produce.

NOTE: Do not use flat stock or round stock larger than listed in the specifications.

2. Move the Adjustable Wheel (16#) up or down (as desired) by turning the Knob (29#)
3. To obtain small size rings, (approximately 25mm) the Adjustable Wheel (16#) must be in its uppermost position.
4. To obtain 50mm rings, the Adjustable Wheel-(16#) must be in the middle position.
5. To obtain larger rings, the Adjustable Wheel (16#) must be in its lowest position. It is recommended that you practice on scrap stock to find the correct wheel adjustment to make the desired size ring.
6. Insert the stock between the Upper Drive Wheel (4#) and between both the Adjustable Wheel (16#) and lower Drive Wheel (4#).
7. Turn the Knob (29#) clockwise to clamp the stock between the Wheels.

NOTE: After stock has been clamped between the Wheels, keep hands and fingers clear of the Wheels while the handle is being rotated.

8. Rotate the Handle (15#) counterclockwise to process the ring.
9. To remove the completed rings, turn the Knob (29#) counterclockwise to loosen the clamping action.

MAINTENANCE

CLEANING: Regularly clean the work surfaces using a non-toxic solvent.

LUBRICATION:

There are three lubrication points.
The Drive Shaft (9#), Drive Shaft II (17#) and the Adjustable Shaft (18#). Grease using the grease nipples (1#).

STORAGE:

Store in a dry area out of the reach of children.



WARNING

The machine is the sole responsibility of the owner for its safe use. This responsibility includes but is not limited to proper installation in a safe environment, personnel training, proper inspection and maintenance, manual availability and comprehension. The manufacturer will not be held liable for injury or property damage from negligence, improper training, machine modifications or misuse.



WARNING!

Machines are safeguarded to protect the operator from injury or death with the placement of guards. Machines must not be operated with the guards removed or damaged.

SPARE PARTS SECTION

MANUAL SECTION ROLLING MACHINE

Model. RR-5G

Order Code S680

EDITION No : RR-5G-2
DATE OF ISSUE : 10/2022

The following section covers the spare parts diagrams and lists that were current at the time this manual was originally printed. Due to continuous improvements of the machine, changes may be made at any time without notification.

HOW TO ORDER SPARE PARTS

1. Have your machines **model number, serial number & date of manufacture** on hand, these can be found on the specification plate mounted on the machine
2. A scanned copy of your parts list/diagram with required spare part/s identified.

NOTE: SOME PARTS MAY ONLY BE AVAILABLE AS AN ASSEMBLY

3. Go to www.machineryhouse.com.au/contactus and fill out the inquiry form attaching a copy of scanned parts list.

SPARE PARTS LIST

Item	DESCRIPTION	Qty.		Item	DESCRIPTION	Qty.
1	Zerk Fitting M8X1	3		15	Handle	1
2	C-Ring 18mm	5		16	Adjustable Wheel	1
3	Hex Bolt M10X60	1		17	Drive Shaft II	1
4	Drive Wheel	2		18	Adjustable Shaft	1
5	Left Frame	1		19	C-Ring 22mm	1
6	Copper Bushing	2		20	Taper Pin 8X28	1
7	Stand	1		21	Hex Key Screw M10X60	2
8	Bushing	1		22	Shaft(w/hole)	1
9	Drive Shaft I	1		23	Hex Key ScrewM10X20	2
10	Key 4X16	4		24	Pin 3X12	1
11	Right Frame	1		25	Base	1
12	Gear	2		26	Knob	1
13	Cover	1		27	Lead Screw	1
14	Screw M5X40	2		28	Taper Pin 3X18	1

NOTE: SOME INDIVIDUAL PARTS MAY ONLY BE AVAILABLE AS AN ASSEMBLY

SPARE PARTS DIAGRAM

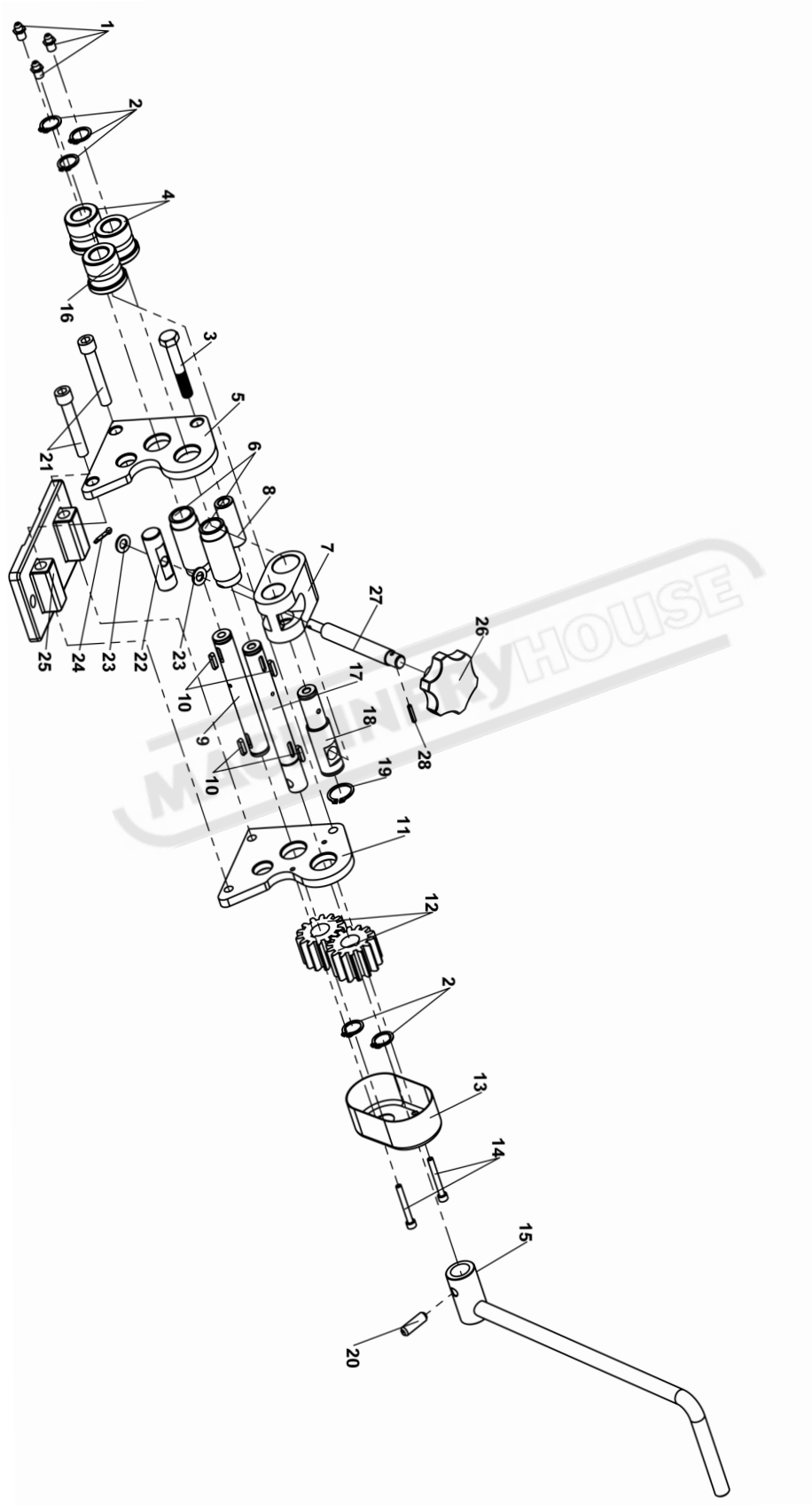

WARNING

General Machinery Safety Instructions

Machinery House
requires you to read this entire Manual before using this machine.

- 1. Read the entire Manual before starting machinery.** Machinery may cause serious injury if not correctly used.
- 2. Always use correct hearing protection when operating machinery.** Machinery noise may cause permanent hearing damage.
- 3. Machinery must never be used when tired, or under the influence of drugs or alcohol.** When running machinery you must be alert at all times.
- 4. Wear correct Clothing.** At all times remove all loose clothing, necklaces, rings, jewelry, etc. Long hair must be contained in a hair net. Non-slip protective footwear must be worn.
- 5. Always wear correct respirators around fumes or dust when operating machinery.** Machinery fumes & dust can cause serious respiratory illness. Dust extractors must be used where applicable.
- 6. Always wear correct safety glasses.** When machining you must use the correct eye protection to prevent injuring your eyes.
- 7. Keep work clean and make sure you have good lighting.** Cluttered and dark shadows may cause accidents.
- 8. Personnel must be properly trained or well supervised when operating machinery.** Make sure you have clear and safe understanding of the machine you are operating.
- 9. Keep children and visitors away.** Make sure children and visitors are at a safe distance for you work area.
- 10. Keep your workshop childproof.** Use padlocks, Turn off master power switches and remove start switch keys.
- 11. Never leave machine unattended.** Turn power off and wait till machine has come to a complete stop before leaving the machine unattended.
- 12. Make a safe working environment.** Do not use machine in a damp, wet area, or where flammable or noxious fumes may exist.
- 13. Disconnect main power before service machine.** Make sure power switch is in the off position before re-connecting.
- 14. Use correct amperage extension cords.** Undersized extension cords overheat and lose power. Replace extension cords if they become damaged.
- 15. Keep machine well maintained.** Keep blades sharp and clean for best and safest performance. Follow instructions when lubricating and changing accessories.
- 16. Keep machine well guarded.** Make sure guards on machine are in place and are all working correctly.
- 17. Do not overreach.** Keep proper footing and balance at all times.
- 18. Secure workpiece.** Use clamps or a vice to hold the workpiece where practical. Keeping the workpiece secure will free up your hand to operate the machine and will protect hand from injury.
- 19. Check machine over before operating.** Check machine for damaged parts, loose bolts, Keys and wrenches left on machine and any other conditions that may effect the machines operation. Repair and replace damaged parts.
- 20. Use recommended accessories.** Refer to instruction manual or ask correct service officer when using accessories. The use of improper accessories may cause the risk of injury.
- 21. Do not force machinery.** Work at the speed and capacity at which the machine or accessory was designed.
- 22. Use correct lifting practice.** Always use the correct lifting methods when using machinery. Incorrect lifting methods can cause serious injury.
- 23. Lock mobile bases.** Make sure any mobile bases are locked before using machine.
- 24. Allergic reactions.** Certain metal shavings and cutting fluids may cause an allergic reaction in people and animals, especially when cutting as the fumes can be inhaled. Make sure you know what type of metal and cutting fluid you will be exposed to and how to avoid contamination.
- 25. Call for help.** If at any time you experience difficulties, stop the machine and call you nearest branch service department for help.

WARNING

Manual Section Rolling Machine Safety Instructions

Machinery House
requires you to read this entire Manual before using this machine.

- 1. Maintenance.** Make sure sure all moving parts are locked down before any inspection, adjustment or maintenance is carried out.
- 2. Section Rolling Machine Condition.** A Section Rolling Machine must be maintained for a proper working condition. Never operate a Section Rolling Machine that has damaged or worn parts. Scheduled routine maintenance should performed on a scheduled basis.
- 3. Roll Condition.** Never operate a Section Rolling Machine with a damaged or badly worn rolls. Replace if required. Rolls should never be greased or lubricated as rolls will slip the material and will not bend.
- 4. Hand Hazard.** Keep hands and fingers clear from moving parts. Serious injury can occur if hand or finger tips get pinched by rolls and can be dragged into machine.
- 5. Gloves & Glasses.** Always wear leather gloves and approved safety glasses when using this machine.
- 6. Avoiding Entanglement.** Section Rolling Machine guards must be used at all times. Tie up long hair and use the correct hair nets to avoid any entanglement with the Section Rolling Machine moving parts.
- 7. Understand the machines controls.** Make sure you understand the use and operation of all controls.
- 8. Work area hazards.** Keep the area around the Section Rolling Machine clean from oil, tools, chips. Pay attention to other persons in the area and know what is going on around the area to ensure unintended accidents.
- 9. Guards.** Do not operate Section Rolling Machine without the correct guards in place. Necessary guards protect you from injuries by worm-type gearbox and other gears. The only other area which needs to be carefully monitored during use is the rotational area of the rolls.
- 10. Material condition.** Material must be clean of oil and dry. Oily material can slip and will not bend.
- 11. Material hardness.** Make sure your hardness is the same throughout the material, we recommend that you use certified material. Never bend hard steel, glass or fragile material on this machine.
- 12. Feeding material.** Making a tight bend in one pass is not possible. Several passes are needed before you can achieve a certain radius. Tighter curves and full radius always need more passes.
- 13. Call for help.** If at any time you experience difficulties, stop the machine and call you nearest branch service department for help.

PLANT SAFETY PROGRAM

NEW MACHINERY HAZARD IDENTIFICATION, ASSESSMENT & CONTROL

Manual Section Rolling Machine

Developed in Co-operation Between A.W.I.S.A and Australia Chamber of Manufactures
 This program is based upon the Safe Work Australia, Code of Practice - Managing Risks of Plant in the Workplace (WHSA 2011 No10)

Item No.	Hazard Identification	Hazard Assessment	Risk Control Strategies <small>(Recommended for Purchase / Buyer / User)</small>
A	ENTANGLEMENT	HIGH	Eliminate, avoid loose clothing / Long hair etc.
B	CRUSHING	LOW	Secure & support work material. Ensure machine is bolted down.
C	CUTTING, STABBING, PUNCTURING.	MEDIUM	Do not adjust or clean until the machine has fully stopped. Wear gloves to prevent cuts from material.
D	SHEARING	MEDIUM	Do not adjust or clean until the machine has fully stopped. Make sure all guards are secured shut when machine is on. Hands should be kept clear of moving parts such as rolls etc.
F	STRIKING	MEDIUM	Ensure area is kept clear of material being rolled.
O	OTHER HAZARDS, NOISE.	LOW	Wear hearing protection as required.
Plant Safety Program to be read in conjunction with manufactures instructions			



www.machineryhouse.com.au



www.machineryhouse.co.nz

Authorised and signed by:
 Safety officer:

Manager: 

Revised Date: 30th Sept 2014